

Technical Specifications

Capacity	Max 3/6kg	Max 6/15kg	Max 15/30kg	
Multi Interval Type 1/3,000	e=1/2g	e=2/5g	e=5/10g	
Model	SM-100PCS+	SM-100BCS+	SM-100EV+	SM-100H+
Display	32 X 202 Full Dot Matrix Green LCD with Back-Light			
Number of preset keys	56	32	74	76
Memory capacity	1MB (Standard)			
Display resolution	1/3,000			
Paper width	Max 60 mm (Lable) 60 mm (Receipt)			
Printing speed	80 mm/sec (Lable) 105 mm/sec (Receipt)			
Lable size	Maximum 60 (W) X 220 (L)mm			
Power source	AC 220 / 230 (50 / 60 Hz.)			
Standard interface	RS232C, Ethernet, Cash drawer I/F, Wireless LAN I/F (IEEE 802.11b/g) Note: Cash drawer and Wireless LAN are not included.			
Dimensions (mm) (W) X (D) X (H)	383.4 X 419.3 X 552.6	383.4 X 389.3 X 162	386 X 416 X 550	350 X 369 X 844
Net weight	10.5kg	9.7kg	11.1kg	11.5kg

External Dimensions (mm)

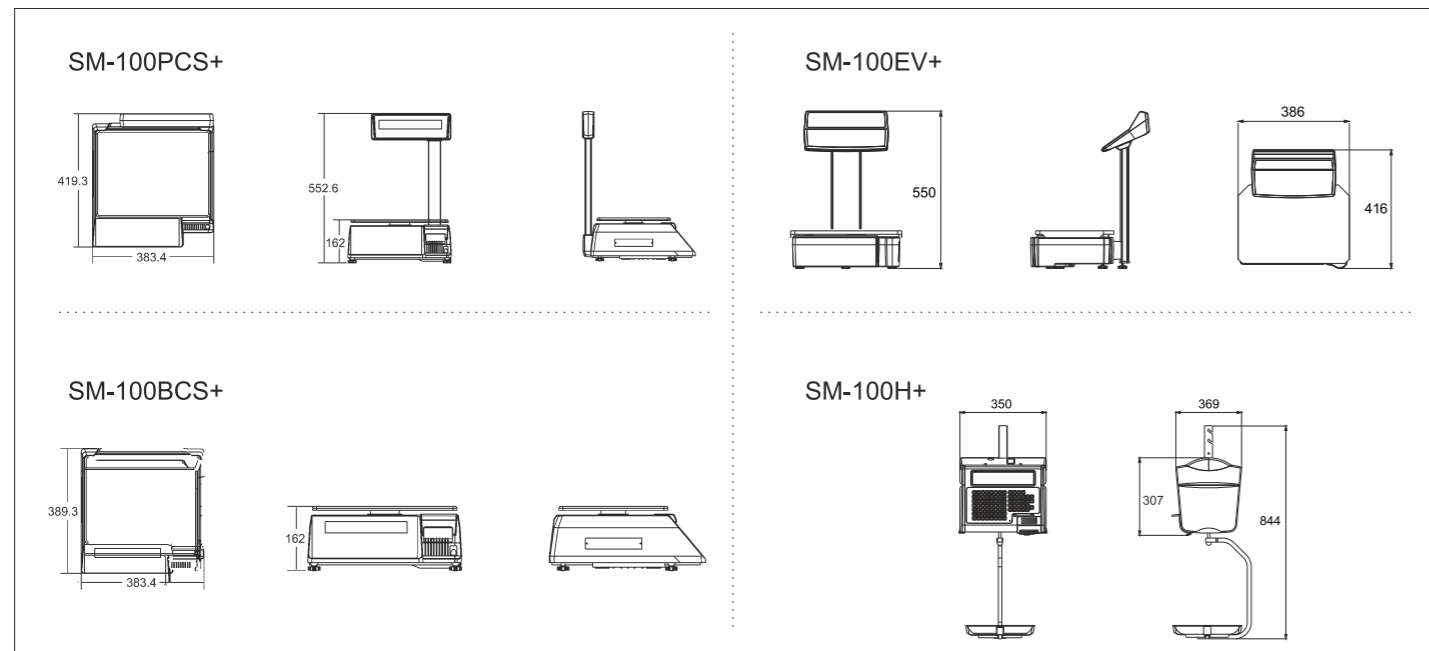

Manufactured by: **Shanghai Teraoka Electronic Co.,Ltd.**



Marketed By:

Essae-Teraoka Pvt. Ltd.

410, 100ft Road, 4th Block,
Koramangala, Bengaluru-560 034

info@essae.com

http://www.essae.com

+91 80 3021 3021

+91 80 3021 3001

1-800-425-3111

0-78488 12346

Essae
...for Excellence

Your Essae representative

▲ Factories in Bengaluru and Goa ▲ 47 Branch Offices ▲ 250+ Service engineers ▲ 350+ Resellers/Partners

Note: The above model meets the statutory and regulatory requirements as per the provision of legal metrology Act 2009 and legal metrology (General) Rule, 2011. Specifications are subject to change without notice. Other names and logos used are property of respective brands.

www.essae.com

Essae
...for Excellence

SM-100+ Scale Printer

Clear Value in a Small Footprint

- Powerful Features.
- Options to meet your operational needs from standalone to wireless networking



Form No. CAT-SM-100+-025 R07



SM-100+

Versatile Scale Printer for store operations

Weigh quickly and print rapidly to increase throughput.

SM-100+ designed to meet the weighing needs of any retail store.

This series provides the best value for your store's operation.



SM-100BCS+
32 Preset Keys



SM-100PCS+
56 Preset Keys



SM-100EV+: Elevated Type
74 Preset Keys

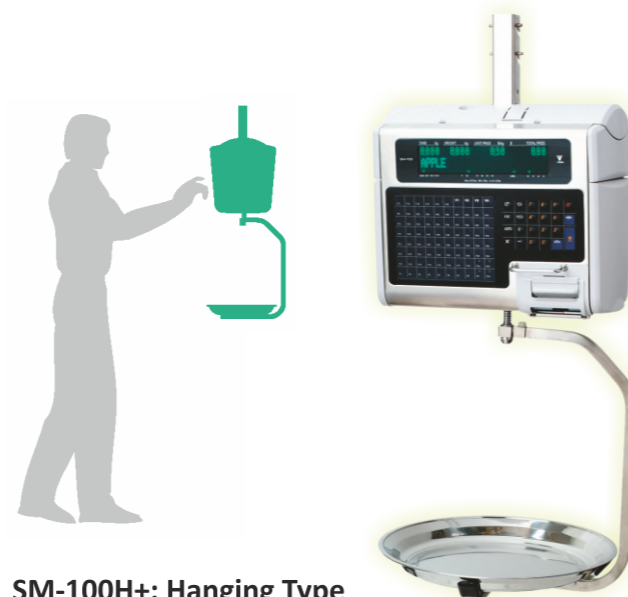

SM-100H+: Hanging Type
76 Preset Keys

Display

- Customers and operators can easily read the bright graphic LCD with back-light.
- Large characters display the product name and scroll messages for promotions or store specials.



Keyboard

Water-resistant membrane keyboard stands up to frequent use.



Reliable printing mechanism

Changing the thermal paper roll is easy through the large opening in the scale housing which enables quick loading of the label or receipt roll.

This access ensures easy handling of rolls and maintenance at the store level, reducing waste, error and costs.

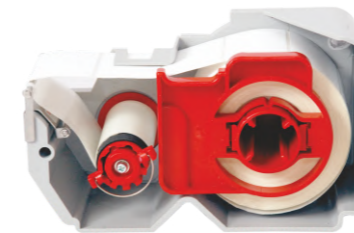

Powerful communication capabilities standard

Through the standard Ethernet or RS-232 interface, inter-scale and store controller communication is readily available.

With the Wireless LAN network interface, scale installation locations can quickly change without added costs. (Wireless network card is optional.)

Quick weight stabilisation and fast label / receipt printing allows the operator to serve more customers and increase volume of the operation.

Barcode Scanner can also be connected to enhance the operation.

Nutritional facts and traceability information can be easily designed and printed for better customer service.