



DS-315

Crane Weigher

Lift your productivity and profits to a new high

- Large and Bright LED display (30mm)
- Long battery backup
- Remote control and display for easy operation
- Ideal for foundries / ladle weightment



Wireless Remote Indicator with Printer (Option)



Thermal Scale with cover



Wireless Remote Display (Option)

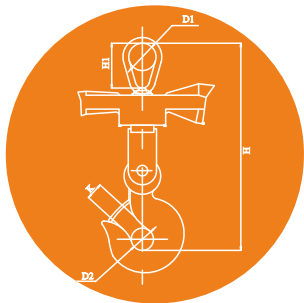

Technical Specifications

- Power supply _____ 230V AC, 50 Hz.
- Power consumption _____ 6W
- Display _____ LED (RED)
- Display digit _____ 5 Digits
- Display size _____ 30mm
- Number of keys _____ 3 Keys
- Battery charger _____ External
- Battery _____ In-built 6V / 7Ah Rechargeable battery
- Remote control _____ Key operation
- Battery operation _____ 40 Hours (When battery is fully charged)

Options:

- Wireless Remote Display
- Thermal Crane Scale
- Wireless Remote Indicator with Printer

Cap / Accu	1Ton/500g	3Ton/1kg	5Ton/2kg	10Ton/5kg	15Ton/5kg	20Ton/10kg	30Ton/10kg
Hook size	201	201	256	316	450	450	560
H	422	477	572	672	985	985	1075
H1	100	100	115	137	255	255	285
K	27	31	48	57	90	90	102
D1	64	64	74	88	139	139	165
D2	36	50	60	70	120	120	120
Thickness of top hook	21	21	27	34	47	47	59
Weight	14	15	21	34	86	86	146

Note: All Dimensions in mm

Essae-Teraoka Pvt. Ltd.

410, 100ft Road, 4th Block,
Koramangala, Bengaluru-560 034

info@essae.com

http://www.essae.com

+91 80 3021 3021

+91 80 3021 3001

1-800-425-3111

0-78488 12346

Essae[®]
...for Excellence

Your Essae representative

▲ Factories in Bengaluru and Goa ▲ 47 Branch Offices ▲ 250+ Service engineers ▲ 350+ Resellers/Partners

Note: The above model meets the statutory and regulatory requirements as per the provision of legal metrology Act 2009 and legal metrology (General) Rule, 2011. Specifications are subject to change without notice. Other names and logos used are property of respective brands.