

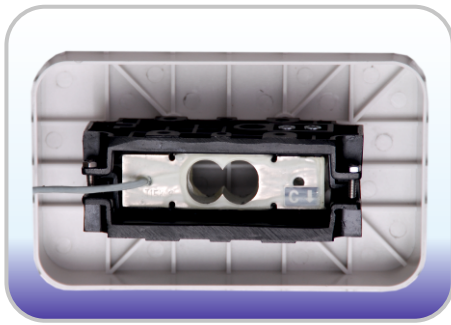

DS-673

Special splash-proof technology and quick response to weight change for food industry, fisheries, pharma and retail





Ip65 loadcell with special environment protection

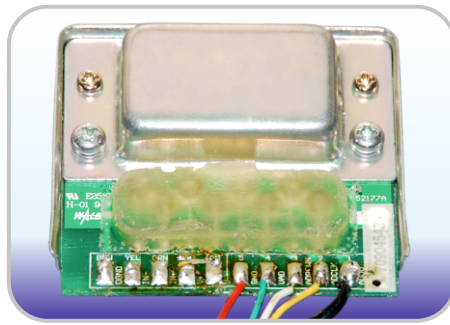

Sealed A/D module



Special housing design for wet area

External Dimensions (mm)

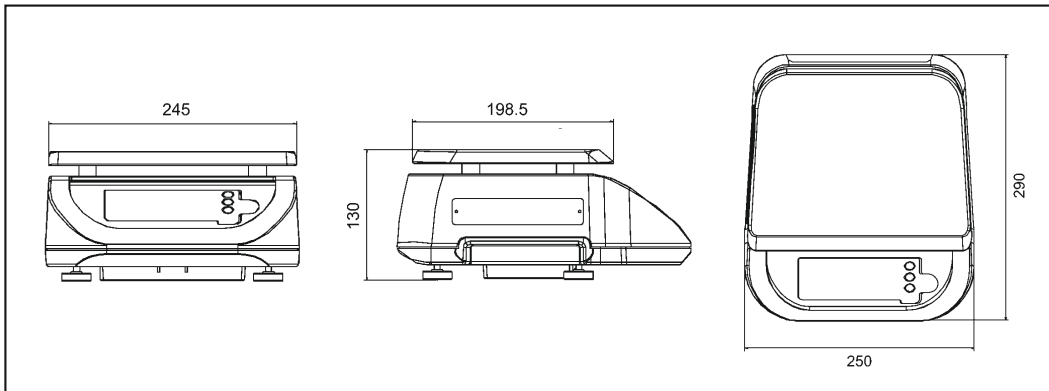

DS-673 Dual display

Key Benefits

- Special water-proof
- Fast response
- Compact and portable
- Dual display is only for DS-673
- Large bright LED display
- Rechargeable battery

Technical Specifications

Model	DS-673
Capacity / Readability	6kg/1g, 15kg/2g
Display	Dual weight display: 6 digits Decimal point: selectable by SPEC
Dimensions	Platter size: 245(W) X 198.5(D) mm Overall size: 250(W) X 290(D) X 130(H) mm
Power source	AC 230V, 50Hz DC 6V /4 Ah rechargeable battery for 48 hours (when fully charged) Charging condition AC 230V (+15% -10%) 50Hz 14 hours
IP protection	IP-65
Power consumption	18W (AC), 3W (DC)

Essae-Teraoka Pvt. Ltd.

✉ 410, 100ft Road, 4th Block,
Koramangala, Bengaluru-560 034
✉ info@essae.com
🌐 http://www.essae.com

☎ +91 80 3021 3021
📄 +91 80 3021 3001
📞 1-800-425-3111
📠 0-78488 12346

Essae®
...for Excellence

Your Essae representative

▲ Factories in Bengaluru and Goa ▲ 47 Branch Offices ▲ 250+ Service engineers ▲ 350+ Resellers/Partners

Note: The above model meets the statutory and regulatory requirements as per the provision of legal metrology Act 2009 and legal metrology (General) Rule, 2011. Specifications are subject to change without notice. Other names and logos used are property of respective brands.